

EGISMOS *DATASHEET*

DPSS Blue Lasers Key features

High Stability and High Reliability

Laser Head Dimension: 143 x 78 x 62mm

Power Supply Dimension: 205 x 144 x 81mm

430/435nm: 1~10mW

457nm: 1~500mW (~9000mW please refer to the high power laser)

473nm: 1~200mW (~1000mW please refer to the high power laser)

501nm: 1~5mW



SXAC473X
Square Laser

DPSS (Diode-Pumped Solid-State) Laser Solutions

A diode-pumped solid-state (DPSS) laser has the beam quality of a gas laser and the small size and efficiency of a diode laser, with single-line output in the violet (430nm, 435nm), Deep blue (457nm), blue (473nm), green (501nm, 515nm, 523nm, 532nm, 543nm, 556nm, 561nm), Yellow (589nm, 593nm), As part of this DPSS laser design, a standard semiconductor diode laser is used to optically pump a small chip of lasing material to generate a fundamental frequency. For blue or green light, a frequency-doubling crystal is inserted into the laser cavity. Finally, extra conditioning optics are added to enlarge and collimate the beam.

EGISMOS DPSS lasers are available for a range of laboratory and industrial applications. Our DPSS lasers are widely used in application areas such as biotechnology, semiconductor instrumentation, inspection and material processing.

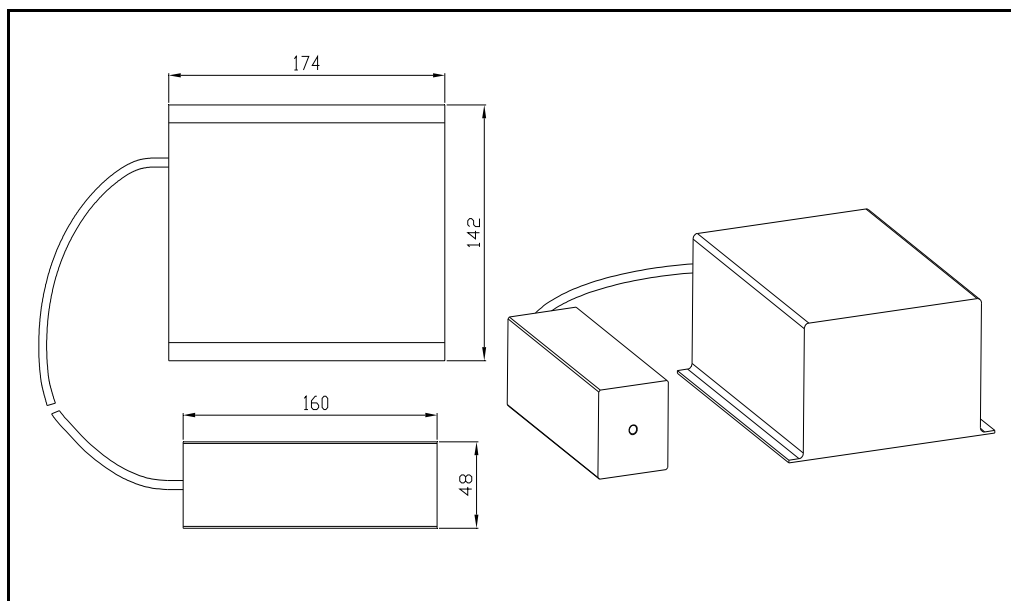

EGISMOS

<http://www.egismos.com>



TEL:+1-888-3481454

FAX:+1-604-4339864

E-Mail:sales@eGismos.com

EGISMOS *DATASHEET*

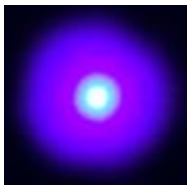
Specifications (typical @tc=25°C)

Item.	Symbol	 SXAC430/435	 SXAC457
Mode		CW, near TEM00	CW, near TEM00
Wavelength	λ	430nm/435nm \pm 1nm	457nm \pm 1nm
Output Power	Po	1~10mW	1~500mW
Dimensions of Laser Head	L x W x H	143 x 78 x 62mm	143 x 78 x 62mm
Dimensions of Power Supply	L x W x H	205 x 144 x 81mm	205 x 144 x 81mm
Warm-up Time		<10min	<10min
Power Stability		<1%, <3%, <5%	<1%, <3%, <5%
Beam Size at the aperture		~2.0mm	~3.0mm
Collimated Beam Divergence		< 1.5mrad	<1.5mrad
Operating Voltage(DC)	Vo	90~250VAC 50/60Hz or 5V DC	90~250VAC 50/60Hz or 5V DC
Operating Temperature	To	15°C~35°C	10°C~35°C
M2 Factor		<1.5	<2.0
Polarization Ratio		>100:1 (0 or 90 degree)	>100:1 (0 or 90 degree)
Modulation		TTL or Analog Modulation	TTL or Analog Modulation
Mean time to failure(MTTF)		10,000 hours	10,000 hours



Laser Safety

The light emitted from these devices has been set in accordance with IEC60825. However, staring into the beam, whether directly or indirectly, must be avoided. IEC60825 classifies laser products into three different categories depending on light emitted, wavelength and eye safety.

CLASS II

"Caution", visible laser light less than 1.0mW. Considered eye safe, normal exposure to this type of beam will not cause permanent damage to the retina.

CLASS IIIR

"Danger", visible laser light between 1.0mW and 5.0mW. Considered eye safe with caution. Focusing of this light into the eye could cause some damage.

CLASS IIIB

"Danger", infrared (IR), and high power visible lasers considered dangerous to the retina if exposed. N B: It is important to note that while complying with the above classifications, unless otherwise stated, our laser diode products are not certified and are designed solely for use in OEM products. The way in which the device is used in the final product may alter its original design classification, and it is the responsibility of the OEM to ensure compliance with the relevant standards.

Egismos

<http://www.egismos.com>



TEL:+1-888-3481454

FAX:+1-604-4339864

E-Mail:sales@eGismos.com

Egismos *DATASHEET*

Specifications (typical @tc=25°C)

Item.	Symbol	 SXAC473	 SXAC501
Mode		CW, TEM00	CW, TEM00
Wavelength	λ	473nm \pm 1nm	501nm \pm 1nm
Output Power	Po	1~200mW	1~5mW
Dimensions of Laser Head	L x W x H	143 x 78 x 62mm	143 x 78 x 62mm
Dimensions of Power Supply	L x W x H	205 x 144 x 81mm	205 x 144 x 81mm
Warm-up Time		<10min	<10min
Power Stability		<1%, <3%, <5%	<1%, <3%, <5%
Beam Size at the aperture		~2.0mm	~2.0mm
Collimated Beam Divergence		< 1.5mrad	<1.5mrad
Operating Voltage(DC)	Vo	90~250VAC 50/60Hz or 5V DC	90~250VAC 50/60Hz or 5V DC
Operating Temperature	To	10°C~35°C	10°C~35°C
M2 Factor		<1.2	<1.2
Polarization Ratio		>100:1 (0 or 90 degree)	>50:1 (0 or 90 degree)
Noise of amplitude		~30% (rms, 1~20MHz)	
Modulation		TTL or Analog Modulation	TTL or Analog Modulation
Mean time to failure(MTTF)		10,000 hours	10,000 hours



Laser Safety

The light emitted from these devices has been set in accordance with IEC60825. However, staring into the beam, whether directly or indirectly, must be avoided. IEC60825 classifies laser products into three different categories depending on light emitted, wavelength and eye safety.

CLASS II

"Caution", visible laser light less than 1.0mW. Considered eye safe, normal exposure to this type of beam will not cause permanent damage to the retina.

CLASS IIIIR

"Danger", visible laser light between 1.0mW and 5.0mW. Considered eye safe with caution. Focusing of this light into the eye could cause some damage.

CLASS IIIB

"Danger", infrared (IR), and high power visible lasers considered dangerous to the retina if exposed. N B: It is important to note that while complying with the above classifications, unless otherwise stated, our laser diode products are not certified and are designed solely for use in OEM products. The way in which the device is used in the final product may alter its original design classification, and it is the responsibility of the OEM to ensure compliance with the relevant standards.

Egismos

<http://www.egismos.com>

TEL:+1-888-3481454

FAX:+1-604-4339864

E-Mail:sales@eGismos.com